

# ***TRAC VAC***

**Model 380/385-IC/385-LH**



## **Operating and Assembly Manual**

**Midwest Equipment Manufacturing, Inc.  
5225 Serum Plant Road  
Thorntown, IN 46071**

# SAFETY RULES

Remember, any power equipment can cause injury if operated improperly or if the user does not understand how to operate the equipment. Exercise caution at all times when using power equipment.



**This symbol means Attention!!!! It is used to point out safety precautions.**

- Read and follow all instructions in this manual before assembly or operation of this equipment. Failure to comply with these instructions may result in personal injury. Keep this manual for future reference and for ordering replacement parts.
- Read this instruction manual carefully. Become familiar with the controls and proper use of this equipment.
- Read the engine owners manual and safe operation rules before using this equipment.
- Never allow children less than 16 years of age to operate the Trac-Vac. Children 16 years and older should operate **only** under close parental supervision.
- Do not allow anyone to operate this equipment without proper instruction.
- Do not allow passengers to ride on the Trac-Vac or on the towing vehicle.
- Keep children and pets out of area of operation.
- Check fuel before starting engine. **Do Not** fill fuel tank indoors, or while engine is running or hot. Wipe off any spilled fuel before starting engine.
- Engine and muffler get **HOT! Do Not** touch! Keep debris from accumulating on or around engine and muffler to avoid fire hazard.
- Allow engine to cool before storing in any enclosed area. Never store Trac-Vac with fuel in tank.
- Do not operate engine if air cleaner or cover is removed, except for adjustments. Removal of the part could create a fire hazard.
- Keep hands, feet, face, long hair and clothing out of inlet and discharge areas. There are **ROTATING BLADES** inside these openings.
- Make certain that all moving parts come to a complete stop before cleaning, repairing or inspection. Disconnect spark plug wire and keep away from plug to prevent accidental starting.
- If Trac-Vac should become clogged with debris, **SHUT OFF ALL ENGINES** and wait until impeller comes to a complete stop before attempting to remove obstruction. Disconnect spark plug wire to prevent accidental starting.
- If excessive vibration occurs while operating your Trac-Vac, stop the engine immediately, disconnect the spark plug wire and allow all moving parts to stop completely before taking the following steps.
  - A. Inspect for damage.
  - B. Repair or replace any damaged parts.
  - C. Check for loose parts and tighten to assure continued safe operation.
- Check all hardware periodically to insure safe operation.
- Check cart cover periodically for wear and replace if worn or damaged.
- **Never** operate Trac-Vac without intake hose and exhaust hose attached in proper place.
- **Do Not** remove exhaust hose or attempt to empty contents of container while engine is running.
- Keep all shields and guards in place and securely attached.
- Always wear eye protection (safety glasses or goggles) when operating this equipment.
- **Do Not** stand behind unit in exhaust discharge area while engine is running.
- **Do Not** operate this equipment while intoxicated or while taking medications that could impair reactions or senses.
- Operate this equipment at reduced ground speed on rough terrain, along creeks and ditches and on slopes to prevent tipping or loss of control.
- Vehicle stability and braking are affected by the addition of this unit. Do not fill the Trac-Vac to its full capacity without checking the capability of the towing vehicle to safely pull and stop with the unit attached.
- **Do Not** operate on slopes in excess of 10 degrees. **STAY OFF OF STEEP SLOPES!**
- Follow the maintenance instructions outlined in this manual.



**CAUTION!!!!  
SPINNING BLADE**

## Model 380/385 Trac-Vac Parts List

<u>Key</u>	<u>Part No.</u>	<u>Description</u>	<u>Qty.</u>
1	38010	Engine Frame, RH	1
	38011	Engine Frame, LH (385-LH)	1
2	38012	Container Frame	1
3	38015	Vertical Upright	1
4	38020	Engine, 3.5 HP B&S (380-)	1
	56021	Engine, 5.5 HP B&S Intek IC (385-)	1
	56018	Engine, 6.5 HP B&S Intek Pro	1
	56017	Engine, 6.5 HP Intec Pro Elec. St.	1
5	56030	Turbine Housing, 6"	1
6	56040	Turbine, 5HP	1
7	56107	Turbine Washer	1
8	56050	Inlet, 6"	1
9	68050	Wheel, Pneumatic	2
10	46233	Filter Support	1
11	46217	Top Support	1
12	56115	Nylon Spacer	3
13	47222	Molded Top	1
14	46228	Filter	1
15	46219	Seal, Molded Top	1
16	46235	Container Latch	1
17	48040	Intake Nozzle	1
18	3120518	Eyebolt	2
19	48038	Spring	2
20	46218	Clevis Pin, Vertical Support	1
21	46210	Container, 44 Gallon	1
22	56102	Hose Clamp, 6"	4
23	46103	Exhaust Hose-HD, 6" x 36"	1
24	48050	Intake Hose, 6" x 80"	1
25	48047	Support Arm	1
26	58072	Hose Support Strap, 6"	1
27	58104	Hitch Pin	1
28	46248	Filter Shield	1
29	38018	Support Arm Bracket	1
30	47411	2" Sq. Bend U-Bolt	1
31	2510108	Turbine Bolt (3.5 HP Briggs)	1
	3120608	Turbine Bolt (5.5 HP Briggs Intek)	1
32	3120612	Housing Bolt	4
33	3750238	Turbine Set Screw	1
34	1871714	Turbine Key	1
35	86115	Exhaust Deflector (5.5HP Briggs only)	1
36	2500801	Turbine Lock Washer (3.5 HP Briggs only)	1
37	***-6	6" Deck Chute Ass'y (Deck Specific)	1
38	58075	Engine Guard	1
	45131	Decal, 2" x 8", Trac-Vac, White	
	45133	Decal, Warning Stop Engine	
	48096	Decal, Danger Stop Engine	
	18110	Key Switch (Elec. Only)	
	56122	Spacer Kit (Elec. St. Only)	

### Optional Accessories:

<u>Key</u>	<u>Part No.</u>	<u>Description</u>
39	150	4" Remote Pickup Assembly
	160	6" Remote Pickup Assembly
40	48066	Tow Kit

# Trac-Vac Model 380/385

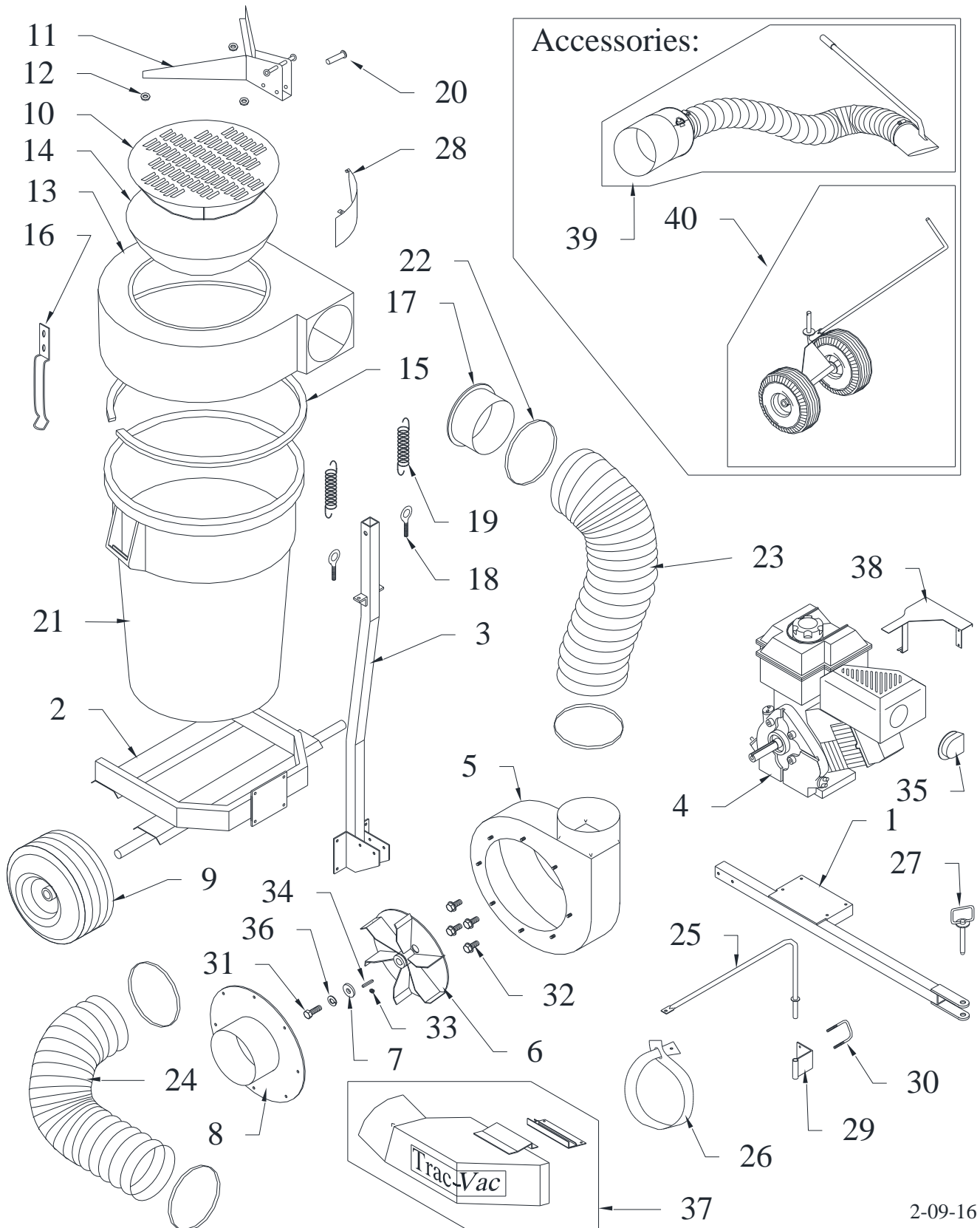

2-09-16

# Model 380/385 Trac-Vac Assembly Instruction

1. Slip wheel (9) over container frame (2) axle pin, trapping 3/4" flatwasher on both sides of wheel. Secure with 1/8" x 1" cotter key. Repeat procedure with opposite wheel. Fig 1
2. Place frame (2) on blocks and level the frame with axles towards the bottom and frame channels facing upwards. Attach vertical upright (3) to container frame bracket with 3/8" x 1" HHC and whizlocks. Do not tighten. Fig. 2
3. Attach eyebolts (18) to vertical upright upper brackets, trapping the brackets between 5/16" hexnut and 5/16" whizlock nuts. Rotate eyebolts so eyelets face from front to back. Fig. 3
4. Place container (21) in container frame. Install foam seal to molded top where container and top will make contact. Set top assembly on can with top support bracket astride the vertical upright. Align pivot hole on top support to hole on vertical upright (3), do not force fit this alignment, if holes do not line up, move vertical upright up or down to the frame (2) until proper alignment is achieved and tighten. Fig. 4. Secure molded top (13) with 1/2" x 2 1/2" HHC and nylock nut. Tighten until slight drag can be felt when pivoting molded top. Pivot top up and attach springs (19) to eyebolts and spring retainers on top support. Lower top assembly to operating position and immediately slip clevis pin (20) thru locking pin hole on top support. Secure pin with 1/8" x 1" cotter key. Attach latch to molded top with 1/4" x 1/2" truss head bolt and 1/4" whizlock nuts. Attach engine frame (1) to vertical upright brackets. Secure with 3/8" x 2 1/4" HHC and flatwasher (under bolt head) and whizlock with nut toward engine. Do not tighten. Attach frame assembly to tractor drawbar with hitch pin (27). Re-level container frame with ground. Now, tighten all bolts. Fig. 5
5. Attach engine assembly to engine frame plate. Secure with two 5/16" x 1 1/4" HHC and two 5/16" x 3" Hexbolts and 5/16" locknuts. Fig. 6
6. Slip exhaust hose over turbine housing (5) neck and tighten clamp. Slip hose clamp (22) over exhaust hose (23) and over intake nozzle (17), and tighten clamp. On the intake side bunch the hose up against the molded top for a good airtight fit. Fig. 7
7. Attach discharge chute to mower deck
8. Slip hose clamps over each end of intake hose (24). Attach to inlet (8) and tighten clamps. Fig. 8
9. Attach support arm bracket (29) to right side of drawbar with U-bolt (30). Slide support arm into bracket tube. Place support strap around hose, thru slit in strap and bolt to support arm. Hang support strap over edge of support arm like pictured, not over the end. Fig. 9
10. Turn tractor to left as sharp as the vacuum will let it for right hand discharge tractors and if necessary shorten intake hose to minimum length. Attach hose to chute and tighten clamp. For left hand discharge tractors use same procedure except turn tractor to the right.
11. Read engine operation instructions and service engine before starting.

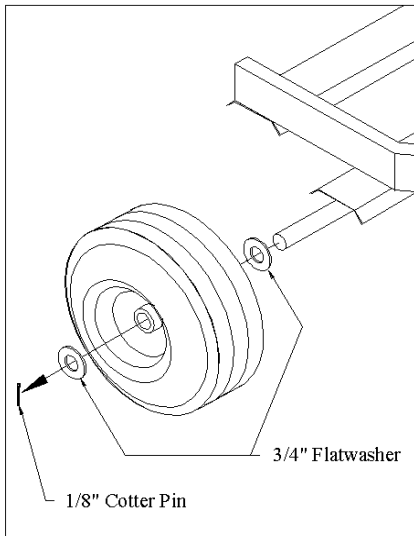

Fig. 1

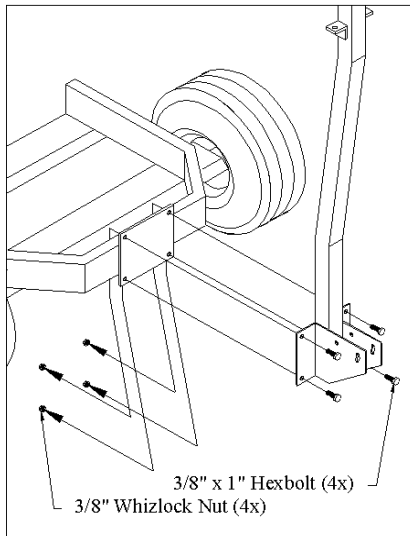

Fig. 2

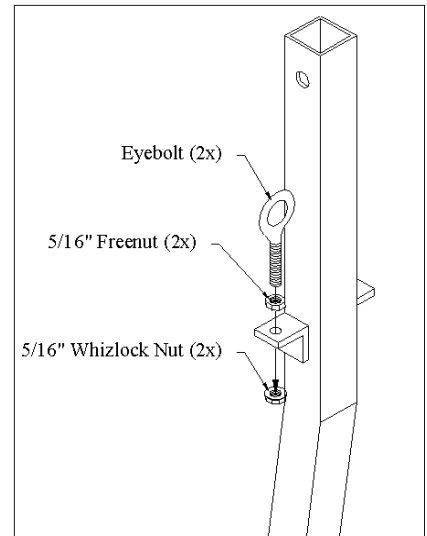

Fig. 3

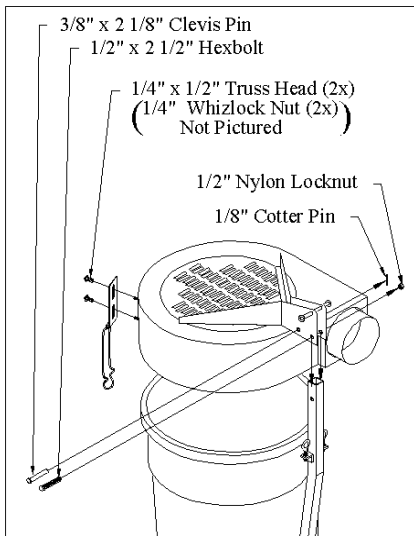

Fig. 4

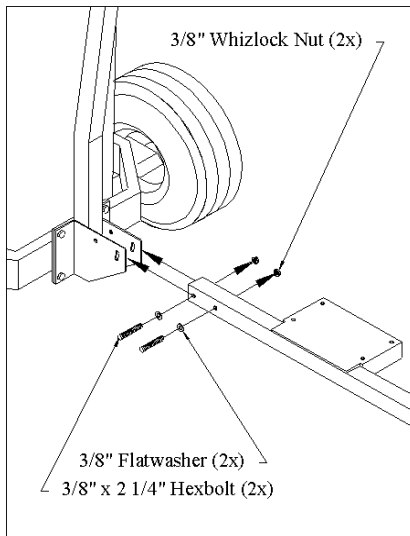

Fig. 5

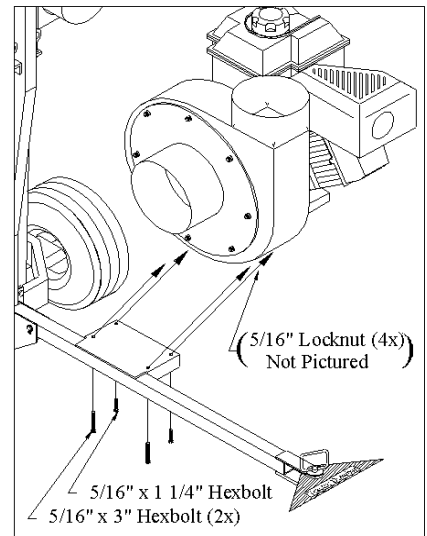

Fig. 6

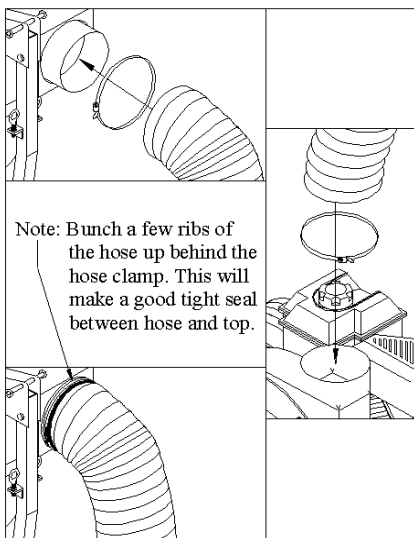

Fig. 7

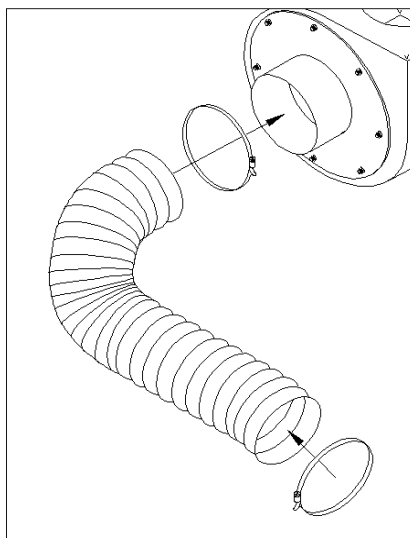

Fig. 8

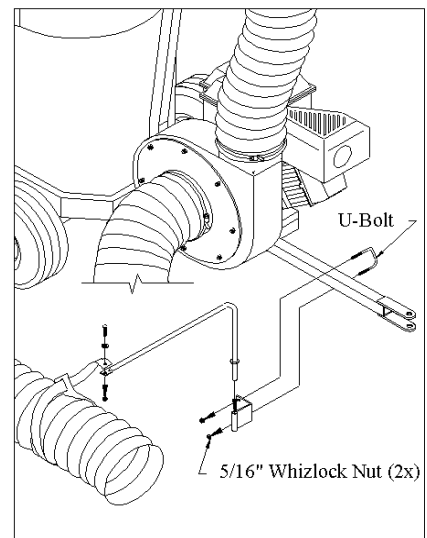

Fig. 9

## TROUBLESHOOTING

<b>PROBLEM</b>	<b>POSSIBLE CAUSE</b>	<b>CORRECTIVE ACTION</b>
Engine fails to start	<ol style="list-style-type: none"> <li>1. Spark plug wire disconnected</li> <li>2. Fuel tank empty</li> <li>3. Faulty spark plug</li> </ol>	<ol style="list-style-type: none"> <li>1. Connect wire to spark plug</li> <li>2. Fill tank with clean fuel</li> <li>3. Clean, adjust gap or replace</li> </ol>
Loss of power or erratic operation	<ol style="list-style-type: none"> <li>1. Spark plug wire loose</li> <li>2. Blocked fuel line</li> <li>3. Water or dirt in fuel system</li> <li>4. Dirty air cleaner</li> <li>5. Unit running on choke</li> </ol>	<ol style="list-style-type: none"> <li>1. Connect &amp; tighten spark plug wire</li> <li>2. Clean fuel line</li> <li>3. Disconnect fuel line at carburetor drain fuel tank. Refill with fresh fuel</li> <li>4. Service air cleaner (refer to engine manual)</li> <li>5. Move choke lever to OFF position</li> </ol>
Engine overheats	<ol style="list-style-type: none"> <li>1. Engine oil level low</li> <li>2. Operating below full RPM</li> </ol>	<ol style="list-style-type: none"> <li>1. Fill crankcase with proper oil</li> <li>2. Run throttle full open.</li> </ol>
Excessive vibration	<ol style="list-style-type: none"> <li>1. Damaged turbine or loose parts</li> </ol>	<ol style="list-style-type: none"> <li>1. Stop engine immediately and disconnect spark plug wire. Tighten all bolts &amp; nuts. Make necessary repairs. If vibration continues, have unit serviced by an authorized dealer.</li> </ol>
Unit won't pick up.	<ol style="list-style-type: none"> <li>1. Discharge chute clogged</li> <li>2. Foreign object lodged in turbine.</li> <li>3. Container full</li> </ol>	<ol style="list-style-type: none"> <li>1. Stop engine &amp; disconnect spark plug wire. Clean inside of discharge chute.</li> <li>2. Stop engine and disconnect spark plug wire. Remove lodged object in turbine.</li> <li>3. Stop engine and empty container.</li> </ol>

**NOTE:** Please contact the nearest authorized service dealer for repairs beyond the minor adjustments above.

# OPERATING PROCEDURE

**BEFORE STARTING**, follow the engine manufacturer's instructions in preparing engine for operation. Never fill fuel tank indoors, with engine running or while engine is hot.

**Do not smoke while filling tank!**



1. Inspect area to be vacuumed and pickup all harmful objects and litter. Rocks and other harmful debris can do serious damage to vacuum assembly and cause bodily injury.
2. For best vacuuming results operate tractor at manufacturer's recommended speed for best cutting. If grass is high, mow first and vacuum on the second pass.
3. Your vacuum is preset to run at approximately 3800-RPM (385), at no load. Do not slow down engine.
4. SHUT OFF ENGINE TO UNLOAD.
5. When operating tractor on slope or grade, exercise **EXTREME CAUTION**. Do not cut across grade or slope. Mow directly up and down hills.
6. Periodically check all fasteners for tightness.
7. Listen for unusual vibration of engine or air turbine. If excessive vibration is present, **STOP** engine and check for damage to turbine fan.
8. Always shut off tractor engine and vacuum engine before servicing.
9. Replace deflector shield when discharge chute is removed.
10. When removing clogs, **SHUT OFF ALL ENGINES and wait for all moving parts to come to a complete stop! Failure to do so can cause serious bodily injury!**
11. Do not tow unit on public roads
12. Do not carry passengers on unit
13. Avoid sudden turns or maneuvers.



CAUTION!!!  
SPINNING BLADE

## EXTENDED STORAGE PROCEDURES

1. Wash and clean vacuum, and lubricate any lubrication points.
2. Drain fuel from the tank and run vacuum until fuel is exhausted in carburetor.
3. Drain and change the engine oil.
4. Clean tires and check pressure. Raising and supporting unit with weight off tires is recommended.
5. When storing a unit with Rubbermaid® containers, leave containers latched to top.
6. Store inside a clean dry area, when not in use.

## TRAC VAC WARRANTY POLICY

Midwest Equipment Manufacturing, Inc. will repair or replace, free of charge, any part, or parts that are defective in material or workmanship or both for a period of one year residential use, and 90 day's for commercial and rental use. The purchaser will pay transportation charges on parts submitted for replacement under warranty. For warranty service, contact your local dealer from whom the unit was purchased. There are no other express or implied warranties. Some states do not allow limitations on how long an implied warranty lasts, and some states do not allow the exclusion or limitation of incidental or consequential damages, so the above limitation and exclusion may not apply to you. This warranty gives you specific legal rights and you may also have other rights, which vary from state to state.

Midwest Equipment Manufacturing, Inc.-5225 Serum Plant Rd.-Thorntown,  
IN 46071

Phone: 1-800-Trac-Vac

Web Page: [www.trac-vac.com](http://www.trac-vac.com) E-Mail: [sales@midmfg.com](mailto:sales@midmfg.com)